

**sewoo**



**MODEL : LK-P34**

MOBILE PRINTER(Wi-Fi & Bluetooth)

**sewoo**

**Aroot Co., Ltd.**

28-6, Gajangsaneopdong-ro, Osan-si, Gyeonggi-do ,18103, Republic of Korea  
TEL +82-31-8077-5000 / FAX +82-31-624-5310 / <http://www.miniprinter.com>

## Following information shall be included in the manual

### Information to User;

#### Caution:

the user that changes or modifications not expressly approved by the J. STEPHEN Lab., Ltd.responsible for compliance could void the user's authority to operate the equipment.

#### NOTE:

This equipment has been tested and found to comply with the limits for a Class B digital device, pursuant to part 15 of the FCC Rules. These limits are designed to provide reasonable protection against harmful interference in a residential installation. This equipment generates, uses and can radiate radio frequency energy and, if not installed and used in accordance with the instructions, may cause harmful interference to radio communications. However, there is no guarantee that interference will not occur in a particular installation.

If this equipment does cause harmful interference to radio or television reception, which can be determined by turning the equipment off and on, the user is encouraged to try to correct the interference by one or more of the following measures:

- Reorient or relocate the receiving antenna.
- Increase the separation between the equipment and receiver.
- Connect the equipment into an outlet on a circuit different from that to which the receiver is connected.
- Consult the dealer or an experienced radio/TV technician for help.

### Responsible Party;

The responsible party for Supplier's Declaration of Conformity must be located within the United States, so you have to include following information in manual.

**This device complies with part 15 of the FCC Rules.  
Operation is subject to the following two conditions.**

- 1) This device may not cause harmful interference, and
- 2) This device must accept any interference received, including interference that may cause undesired operation.

#### Tim Kloeker

19700 S Vermont Ave Ste 200 Torrance, CA 90502 | USA  
NA\_Sales@miniprinter.com

#### Victor Almazan

Paseo de la Reforma No. 265 Piso 2.Oficina SBC. Col.  
Cuauhtémoc, C.P. 06500 Ciudad de Mexico | Mexico  
LA\_Sales@miniprinter.com



**Risk of explosion if battery is replaced by an incorrectly type.  
Dispose of used battery according to the local disposal instructions.**



**Disposal of Old Electrical&Electronic Equipment(Applicable in the European Union and other European countries with separate collection systems)**

This symbol on the product or on its packaging indicates that this product shall not be treated as household waste. Instead it shall be handed over to the applicable collection point for the recycling of electrical and electronics equipment. For more detailed information about recycling of this product, please contact your local city office, your household waste disposal service or the shop where you purchased the product.

# Safety Precautions

For better safety and reliability, adhere to the following precautionary measures.  
Read and follow the instructions carefully before operation of the product.

## Indication



Prohibition



Must follow



Do not disassemble



Unplug the power from the outlet



Grounding to prevent electric shock



Do not handle the product with wet hands



## WARNING

Failure to follow these instructions could result in fire, electric shock, other injuries, or property damage.



Do not pull or touch the power plug with wet hands.

Potential risk of electric shock or fire



Do not bend the wire and do not allow the wire to be pinched or crushed by heavy objects.

Potential risk of electric shock or fire

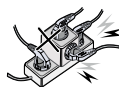

Do not overload an electrical outlet.

Potential risk of electric shock or fire



If a power plug is broken or a plug is cut or worn, do not use it.

Potential risk of electric shock or fire



## WARNING

Failure to follow these instructions could result in fire, electric shock, other injuries, or property damage.



Do not unplug the power cable to turn off the product.

Turn off the power using the power button

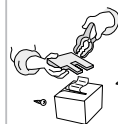

Do not disassemble, repair or modify the product.

Potential risk of malfunction, electric shock, or fire. When the product needs to be repaired, please contact your reseller



## CAUTION

Failure to follow these instructions could result in fire, electric shock, other injuries, or property damage.



Do not install the product on an unstable or inclined surface.

May cause damage or injury



If the product needs to be repaired, please contact your reseller.

Potential risk of fire or unit malfunction



Keep product away from the water and other material.

Potential risk of fire or unit malfunction

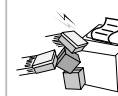

Avoid excessive shock or drops.

Potential risk of fire or property damage



# Table of Contents

Product Overview	
1. Unpacking	6
2. Product Overview	7
3. AMC(Advanced manual cutter) Button	8
4. Control Panel Usage	9
Set Up	
5. Paper Installation	10
6. Battery	11
6-1. Battery Installation	11
6-2. Battery Removal	12
6-3. Battery Charging	13
6-4. Charging Cradle (OPTIONAL)	14
7. Belt Strap	15
8. Self Test	16
Peripheral Connection	
9. Peripheral Connection	18
9-1. Bluetooth Connection (Optional)	18
9-2. Wi-Fi Connection (Optional)	18
9-3. NFC Connection (Optional)	19
9-4. Interface Cable connection	20

Maintenance	
10. Cleaning the Printer	21
11. JAM Error	22
Specification	
12. Roll Media Specification	23
13. Black Mark	24
14. Printer Specification	25
15. Utilities	27
16. S/W	28

# 1. Unpacking

## Standard



Printer

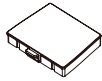

Battery

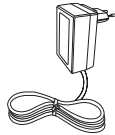

Charger

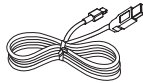

USB Cable

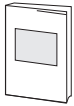

Quick Manual



Belt Strap

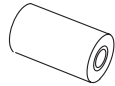

Roll Paper

## Optional

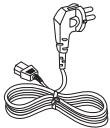

AC Cord

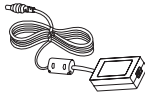

Adaptor

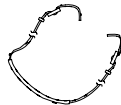

Shoulder Strap

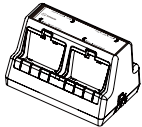

4BC-XX(Charging Cradle)

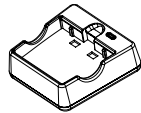

Battery Cradle(Charging Cradle)

# 2. Product overview

## Front

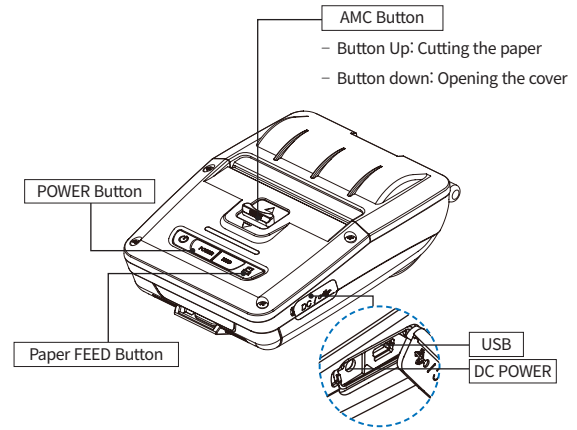

## Rear

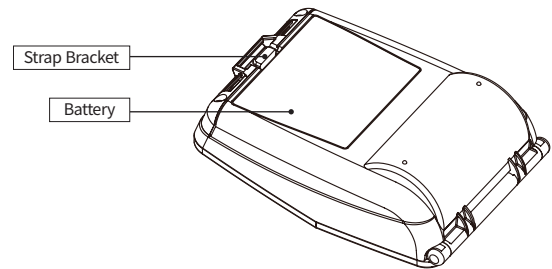

### 3. AMC(Advanced Manual Cutter) BUTTON

AMC function gives the convenient way for users to cut papers.

AMC Button

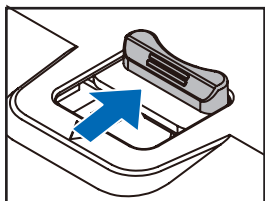
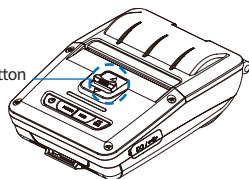

#### Button Up

Press the button up to cut the paper.

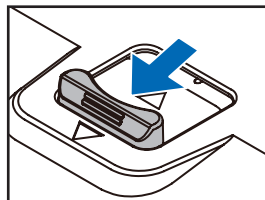

#### Button Down

Press the button down to open the cover.  
Please press the button down and open the cover in situations such as cleaning the head, replacing a paper, and having a paper jam error.

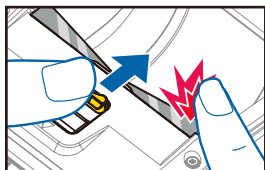

#### CAUTION

Please stay your fingers away from the printer head after pressing up the AMC button with cover open.

There is the risk of finger injury due to a projecting cutter blade.

### 4. Control panel usage

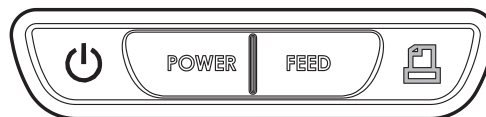

Button	Name	function
	Power Button	<ul style="list-style-type: none"> <li>- This button is used to turn the printer on and off.</li> <li>- When the printer is off, press this button for approximately 3 seconds and the printer will power on.</li> <li>- When you press this button while the printer is powered on, the printer will turn off.</li> </ul>
	Paper Feed Button	<ul style="list-style-type: none"> <li>- This button can be used to manually feed the paper.</li> <li>- Additionally, this button is also used to initiate self-tests and Hexadecimal Dumping.</li> <li>01 Refer to the Self Test section of this manual for information regarding self-tests.</li> <li>02 Refer to the Note in Self Test section of this manual for information regarding Hexadecimal Dumping.</li> </ul>
	Battery Status Lamp	<ul style="list-style-type: none"> <li>- If the Batt LED is lit, the battery is fully charged.</li> <li>- If you can hear a beeping sound and LED light is turned off, the battery is at the lowest level.</li> <li>- If the battery is not charged at all, the printer turns off automatically.</li> </ul>
	Error Lamp	<ul style="list-style-type: none"> <li>- If the red light is turned on, there is no paper or the paper cover is open.</li> </ul>
	LINK/Power Light	<ul style="list-style-type: none"> <li>- LINK: LED BLINK</li> <li>- POWER ON: GREEN LED ON</li> <li>- POWER OFF: LED OFF</li> </ul>

## 5. Paper Installation



**CAUTION**  
Make sure to be careful of the HOT head

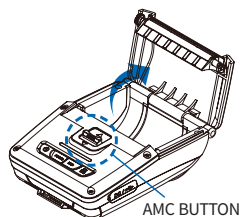

Press the AMC button down to open the paper cover.

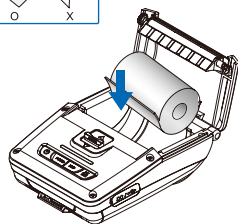
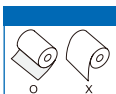

Place the paper roll as shown. Make sure the paper is placed in the right direction.



**CAUTION**  
Please make sure you hear the closing sound of the upper cover.



**CAUTION**  
If the cover is not shut down completely, the printer may not work properly

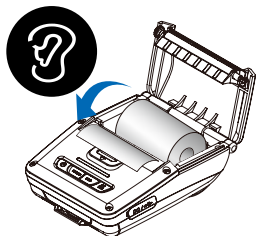

Pull a short length of paper out of the printer and close the cover.



Press the AMC button up to cut the unnecessary paper.

## 6. Battery

### 6-1. Battery Installation

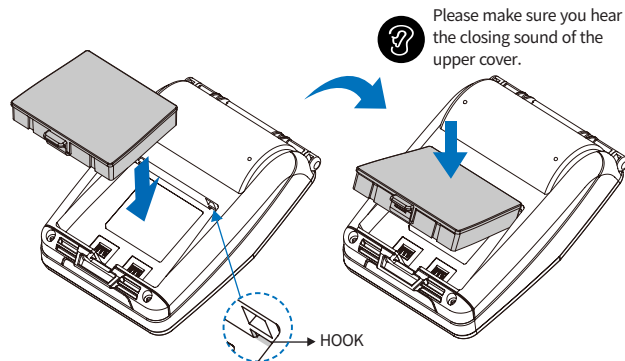

- 1 Align battery hook as shown in the picture.
- 2 Push the battery into the printer until it locks in place.

#### NOTE

As the battery is not charged at the time of your purchase, charge the battery prior to using the printer.

## 6-2. Battery Removal

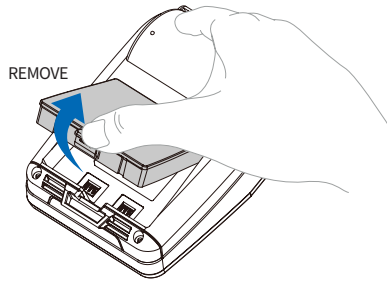

Remove the battery as shown.

## 6-3. Battery Charging

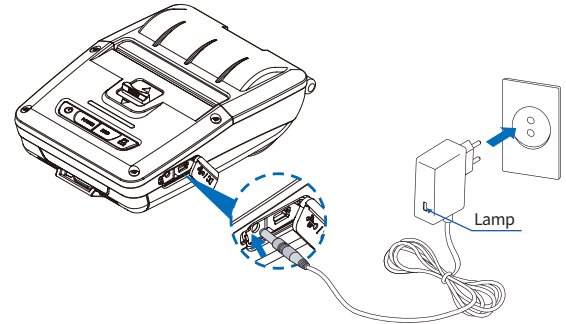

- 1 Make sure the printer is turned off.
- 2 After opening the DC JACK cover, connect the DC JACK to the printer.
- 3 Plug the power cord into the electrical outlet.

Status	charging	charging complete
Charging Lamp	Red	Green

### ✓ NOTE

- 01 If the charger provided by the manufacturer is not used, the printer can be damaged, and the manufacturer is not liable for the consequential damage.
- 02 Before removing the battery, make sure that power is turned off.
- 03 The printer does not work when only connected to the charger.
- 04 The battery needs to be installed to operate the printer.
- 05 While charging, do not turn on the power.
- 06 Do not operate the printer while charging the battery.
- 07 Do not connect the charger while the printer is operating.



## 6-4. Charging Cradle Optional

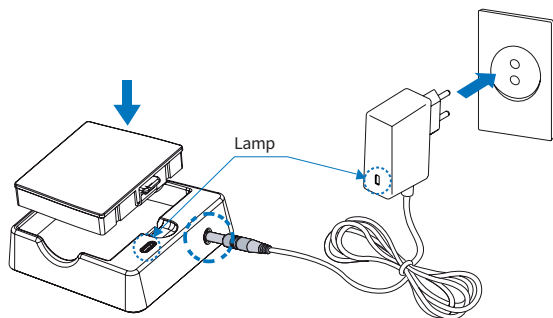

- 1 Insert the battery into the battery charger as shown above.
- 2 Connect the DC JACK to the electrical outlet.
- 3 Plug the power cord into the electrical outlet.
- 4 Once the charging is completed, remove the battery from the charger.

### The charging status LED

Status	charging	charging complete
Charging Lamp	Red	Green

#### NOTE

In the case the battery is not inserted properly, the red LED will blink. Remove and reinsert the battery.

## 7. Belt Strap



Prepare the belt strap.

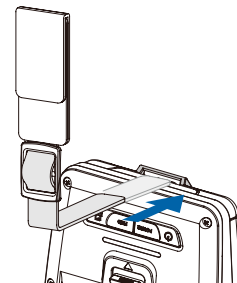

Put the strap into the strap bracket hole as shown.

1 2  
3 4

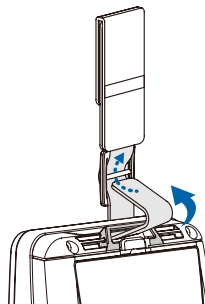

Turn the strap and printer over and put the strap into the hook as shown.

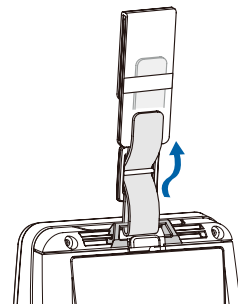

Adjust the strap length for the user's convenience.

## 8. Self Test

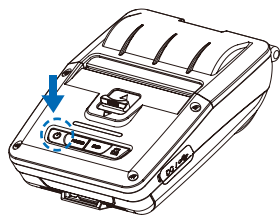

Turn off the power by pressing the power button for approximately 3 seconds.

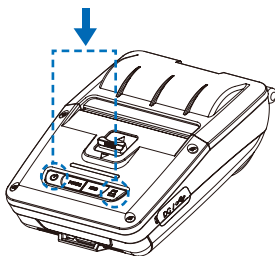

While you are holding the FEED button, press the power button.

1 2  
3

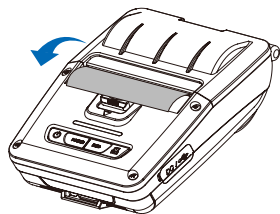

The self-test will print.

### NOTE

- 01 To enter hex dump mode, press the FEED button once more.
- 02 If the FEED button is not pressed, the self-test will automatically finish after 3 seconds.

## Self-Test Printout Sample

### SEWOOD, LK-P34

Printer Configuration Info.  
 F/W Version : v1.00  
 FontRom Version : v1.3  
 BM(Adj) : 151(148)  
 Sensor Mode: [BAR]  
 Battery : 7.9V(796).offset:0  
 Timeout(Sleep) : 60 sec  
 Ext' Flash : Exist  
 H/W Version : v2.0  
 SDRAM : 6MB  
 Linerless : Disabled

Emulation Configuration Info.  
 Emulation : ESC/POS  
 Print Density : Normal(0)  
 Language : Korean  
 연 구 원 상 행  
 Top of Form : 0  
 Top Margin : 0  
 Left margin : 0

USB Interface  
 Version 2.0 Full speed  
 compliant  
 Product String : LK-P34

Bluetooth Interface  
 Version : v0184  
 Device Name : SW\_61fd  
 Mode : SPP\_IAP\_MODE  
 Pairing Info : SSP\_MODE  
 Class Type : PRINTER\_CLASS  
 Auto connection: Enabled  
 BLE : Disabled  
 Address : 88:8b:0f:4e:61:fd



```

*****
!"#$%&'()*+,-./0123456789:;<=?
@ABCDEFGHIJKLMNPQRSTUWXYZ[\]_
`abcde fghi jklmnopqrstuvwxyz{|}~
*****
  
```

\*\*\*\*\*  
 Press FEED button to  
 enter HEX-DUMP mode.  
 \*\*\*\*\*

Upon initial installation or for troubleshooting, you can run the diagnostic test to get information about:

- Firmware version, emulation, codepage, sensor settings, interface settings, etc.

If no issues are found with the diagnostic test, examine other devices and software.

The diagnostic test is working independently of devices and software.

### ※ Motor protection from being overheated

To prevent the motor from overheating, stop the printer for at least 30 seconds after continuously printing 1.5 meters.

## 9. Peripheral Connection

This product can communicate with other devices via Bluetooth, Wi-Fi, or a communication cable.

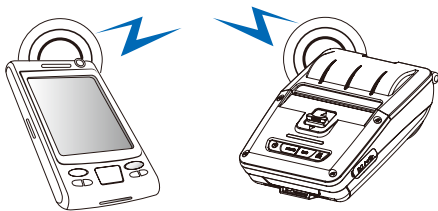

### 9-1. Bluetooth Connection Optional

- 1 The Printer can be connected to devices equipped with Bluetooth communication capabilities (PDAs, PCs, etc.).
- 2 Use the Bluetooth connection function supported by your device to connect to the printer.

#### ✓ NOTE

- This model supports Numeric Comparison function.
- Please refer to the configuration manual for details.

### 9-2. Wi-Fi Connection Optional

- 1 The Printer can be connected to devices equipped with Wi-Fi communication capabilities (PDAs, PCs, etc.).
- 2 Use the Wi-Fi connection function supported by the device to connect to the printer.

#### ✓ NOTE

- Please refer to the configuration manual for details.

### 9-3. NFC Connection Optional

The printer can be connected to devices equipped with NFC communication capabilities.

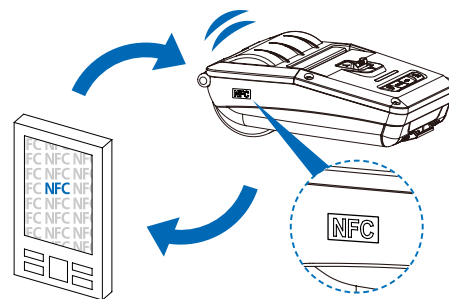

Use the NFC connection function supported by the device to connect to the printer.

#### ✓ NOTE

- Please refer to the configuration manual for details.
- NFC is only compatible with Bluetooth.

## 9-4. Interface Cable Connection

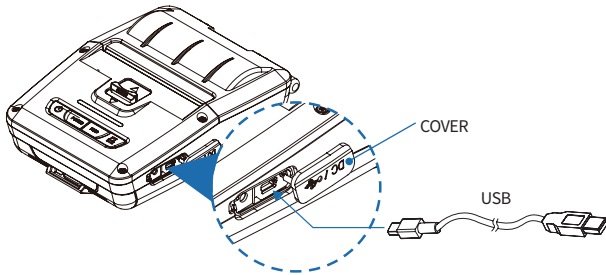

- 1 Flip over the connector cover and connect USB cable to the printer connector.

### ✓ NOTE

Only use cables included with the printer. (USB)

- 2 Connect the interface cable to the USB port of the device (PDA, PC, etc.).

## 10. Cleaning the Printer

If the interior of the printer is dusty, printing quality can be reduced.

In this case, follow the instructions below to clean the printer.

### ✓ NOTE

- 01 Make sure to turn the printer power off prior to cleaning.
- 02 Regarding printhead cleaning, as the printhead gets very hot during printing, turn off the printer power and wait approximately 10 minutes before cleaning.
- 03 When cleaning the printhead, take care not to touch the heated portion of the printhead. The printhead can be damaged by static electricity.
- 04 Take care not to allow the printhead to become scratched and / or damaged in any way.

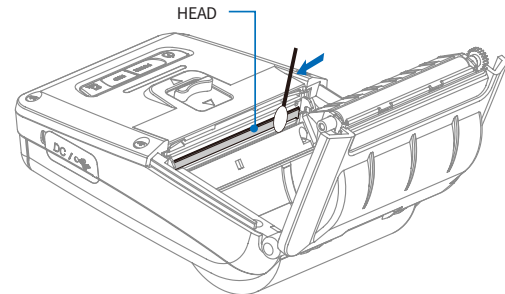

- 1 Use an applicator swab moistened with an alcohol solution to clean the printhead and remove any dust.
- 2 Once the cleaning is completed, wait a few minutes before inserting the paper roll into the printer.

### ✓ Preventing Overheating

To prevent the motor from overheating, stop the printer for at least 30 seconds after continuously printing 1.5 meters.

## 11. JAM Error

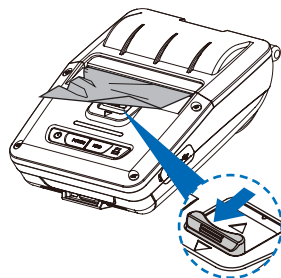

When you face with a paper jam error, please press the button down to open the printer cover.



**CAUTION**  
Make sure to be careful of the HOT head.

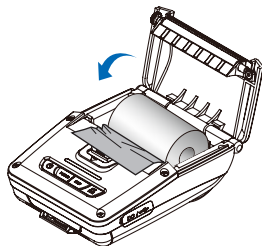

Please remove the paper.

1 2  
3



**NOTE**  
Please make sure you hear the closing sound of the upper cover.



**NOTE**  
If the cover is not shut down completely, the printer may not work properly



After removing, close the cover. The printer will work normally.

## 12. Roll Media Specification

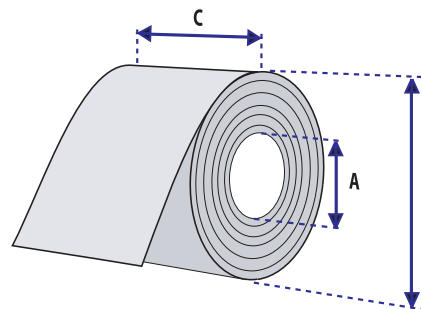

Core	
Diameter (A)	12.5 mm
Roll	
Max.Diameter (B)	50 mm
Max.Media Width (C)	80 mm
Min.Media Thickness	0.06 mm



Protect the printhead from sand, grit, and other hard particles during printing and storage. Keep the cover closed.  
Even very small foreign particles may cause severe harm to the printhead.

## 13. Black Mark

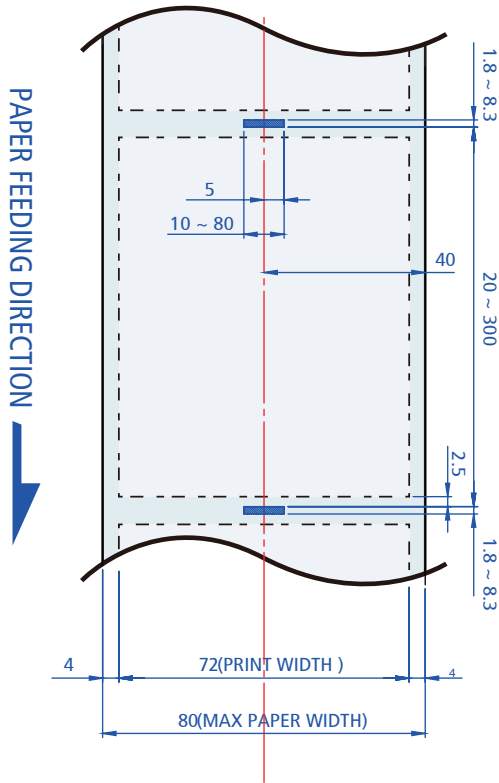

## 14. Printer Specification

Printing Method	Direct Thermal	
Printing Speed	Max. 100mm/s	
Resolution	203 DPI	
Character	Font A(12×24), Font B(9×17), Asian Font(KOR,JPN,CHN-GB2312,CHN-Big5), Font0/1/2/4/5/6/7, Resident TTF, Downloadable TTF, FontA~H, FontGS, Resident TTF(Font0), Font 1~8	
Barcode	1D	EAN-8,EAN8(+2+5), EAN-13, EAN13(+2+5), Codabar, Code11, Code39, Code93, Code128, ITF, LUPC-A(+2+5), UPC-E, UPC-E(+2+5), Planet, UPC-A etc
	2D	PDF417, QR, Maxicode, RSS14, TLC39, Datamatrix, Aztec, MicroPDF417
Emulation	ESC/POS, CPCL, ZPL Command compatible	
Driver	Windows Driver(XP ~, Server2003 ~), Window CE & Mobile Driver & SDK (CE 4.2~, Mobile 5.0~), Linux Driver, Mac Driver, OPOS Driver, JavaPOS Driver, iOS SDK, Android(6.0 ~) SDK	
Sensor	Black mark, Paper end	
Paper	Paper type	Thermal Receipt
	Width	Max. 80mm
	Thickness	0.06-0.09mm
	Roll Max Diameter	Max. 50mm
	Roll Core	12.5mm

## 15. Utilities

The following utilities and concerned manual can be found on the QR or homepage.

No.	Name	Description
1	Configuration Tool	This is a utility that allows you to set printers by interface. Detailed settings such as Wi-Fi, Ethernet, and COM ports can be configured.
2	Download Tool(F/W)	Printer F/W and Font Download are available, and BT, Wi-Fi module F/W Download is supported. - P22, 2011 can download ICR F/W. - BT/Wi-Fi Download function is not supported for P400, P21, P25. - P400 supports SD Card Download function instead of Font Download.
3	NVUpload (ESC/POS)	With NVUpload running on Windows OS, you can upload and remove the bmp file as Logo in the printer's flash memory, and print test is possible.
4	Bitmap Font Download(CPCL)	It is a utility that allows you to change Windows Fonts stored on your PC into Bitmap Fonts for use on the printer.
5	LabelMaker(CPCL)	This program is for label form design and designed label printing.
6	Android Utility (Sewoo M_UTILITY) (ESC/POS)	It is a utility app that prints text, barcodes, images, etc. through Bluetooth and Wi-Fi communication, and able to printer settings.

Interface	Standard	USB
	Option	Wi-Fi(802.11a/b/g/n) or Bluetooth Smart ready(Bluetooth 4.2+BLE)
Battery Charger	Input	AC100~240V, 50/60Hz
	Output	8.4V , 800~1400mA
Battery	Type	Li-ion
	Output	7.4V, 2000mAh
	Charging time	2.7Hrs (61Hrs stand-by)
Cutter	AMC(Advanced Manual Cutter)	
Size	107.5 x 145 x 56 [W x D x H (mm)]	
IP	IP54	
Weight	415.3g (with Battery)	
Temperature	Operation	-10~50°C
	Storage	-20~60°C
Humidity	Operation	10 ~ 80%
	Storage	10 ~ 90%

## 16. S/W

We provides SDK, Driver, etc. as follows to respond to various S/W usage environments.

You can download this S/W from the homepage.

No	Name	Description
1	Windows Driver	This is an install program used to print a Mobile printer in Windows OS.
2	Linux Driver	This is the Cups Driver used to print a Mobile printer in the Linux environment.
3	OPOS Driver (ESC/POS)	This is a driver that controls Mobile printers using the OPOS standard. It can be used after initial setting(Mobile Printer&MSR) using the setting tool.
4	JavaPOS Driver (ESC/POS)	JavaPOS driver is an interface standard for POS software written in Java, and can be used in Mobile Printer when printing a receipt.
5	Mac Driver	This is the Cups Driver used to print a Mobile printer in the Mac OS environment.
6	Android Plugin (Sewoo Print Service Plugin) (ESC/POS)	This is a print service plug-in that allows you to print documents, images, and web pages without installing additional apps.
7	Windows SDK	This is library for communication and data output with Mobile printer in Windows OS.
8	Android SDK	This is library for communication and data output with Mobile printers in Android OS.
9	iOS SDK	This is library for communication and data output with Mobile printers in iOS.



QR Page