

**sewoo**

**sewoo**

**Aroot Co., Ltd.**

28-6, Gajangsaneopdong-ro, Osan-si, Gyeonggi-do, 18103, Republic of Korea

TEL : +82-31-8077-5000 / FAX : +82-31-624-5310

<http://www.miniprinter.com>

TS400 ENG Rev.J 11/2023



## **MODEL : SLK-TS400 SERIES**

Mini Printer User's Manual

All specifications are subject to change without notice

**This device complies with part 15 of the FCC Rules.**

**Operation is subject to the following two conditions.**

- 1) This device may not cause harmful interference, and
- 2) This device must accept any interference received, including interference that may cause undesired operation.

Tim Kloeker

19700 S Vermont Ave Ste 200 Torrance, CA 90502 | USA  
NA\_Sales@miniprinter.com

Victor Almazan

Paseo de la Reforma No. 265 Piso 2.Oficina SBC. Col.  
Cuauhtémoc, C.P. 06500 Ciudad de Mexico | Mexico  
LA\_Sales@miniprinter.com

## For USA

**Information to user;**

**Caution:** The user that changes or modifications not expressly approved by the Aroot Co., Ltd., responsible for compliance could void the user's authority to operate the equipment.

**NOTE: This equipment has been tested and found to comply with the limits for a Class B digital device, pursuant to part 15 of the FCC Rules. These limits are designed to provide reasonable protection against harmful interference in a residential installation. This equipment generates, uses and can radiate radio frequency energy and, if not installed and used in accordance with the instructions, may cause harmful interference to radio communications. However, there is no guarantee that interference will not occur in a particular installation. If this equipment does cause harmful interference to radio or television reception, which can be determined by turning the equipment off and on, the user is encouraged to try to correct the interference by one or more of the following measures:**

- Reorient or relocate the receiving antenna.
- Increase the separation between the equipment and receiver.
- Connect the equipment into an outlet on a circuit different from that to which the receiver is connected.
- Consult the dealer or an experienced radio/TV technician for help.

**CAUTION: Radio Frequency Radiation Exposure**

This equipment complies with FCC radiation exposure limits set forth for an uncontrolled environment and meets the FCC radio frequency RF Exposure Guidelines. This equipment should be installed and operated keeping the radiator at least 20cm or more away from person's body.

**Responsible Party;**

**Company name :** AROOT USA, INC.

**Address :** 19700 S. VERMONT AVE. STE 200 TORRANCE, CA 90502

**Tel/FAX No :** +1-859-992-5936

**Homepage :** miniprinter.com

## For Canada

This class B digital apparatus complies with Canadian ICES-003  
Cet appareil numérique de la classe B est conforme la norme NMB-003 du Canada

The antenna cannot be removed (and changed) by user.

### NOTE

This device contains licence-exempt transmitter(s)/receiver(s) that comply with Innovation, Science and Economic Development Canada's licence-exempt RSS(s). Operation is subject to the following two conditions: (1) This device may not cause interference. (2) This device must accept any interference, including interference that may cause undesired operation of the device.

### CAUTION : Radio Frequency Radiation Exposure

This equipment complies with IC radiation exposure limits set forth for an uncontrolled environment and meets RSS-102 of the IC radio frequency (RF) Exposure rules. This equipment should be installed and operated keeping the radiator at least 20cm or more away from person's body.

---

Use of the Made for Apple badge means that an accessory has been designed to connect specifically to the Apple product(s) identified in the badge, and has been certified by the developer to meet Apple performance standards.

Apple is not responsible for the operation of this device or its compliance with safety and regulatory standards.

---

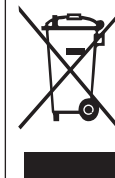

**Disposal of Old Electrical & Electronic Equipment (Applicable in the European Union and other European countries with separate collection systems)**

This symbol on the product or on its packaging indicates that this product shall not be treated as household waste. Instead it shall be handed over to the applicable collection point for the recycling of electrical and electronics equipment. For more detailed information about recycling of this product, please contact your local city office, your household waste disposal service or the shop where you purchased the product.

# Table of Contents

1. Parts Identifications	3
2. Setting up the printer	4
2.1 Unpacking	4
2.2 Connecting the cables	5
2.3 Loading the roll paper	8
3. Control panel and other functions	11
3.1 Control panel	11
3.2 Error Indicating	11
4. Self Test	12
5. ASCII Print	13
6. ECO Mode	13
6.1 Font	13
6.2 Paper Reduce	14
6.3 Density	14
7. Printer Setting	15
7.1 Baudrate	15
7.2 Cutter	15
7.3 Error Beep	15
7.4 Melody	16
8. Hexadecimal Dump	17
9. Peripherals Connection (Option)	18
9.1 Bluetooth Connection	18
9.2 Wi-Fi Connection	18
10. Printer Cleaning	19
11. Specifications	20
12. Command List	22
13. Utilities	24
14. S/W	25

# 1. Parts Identifications

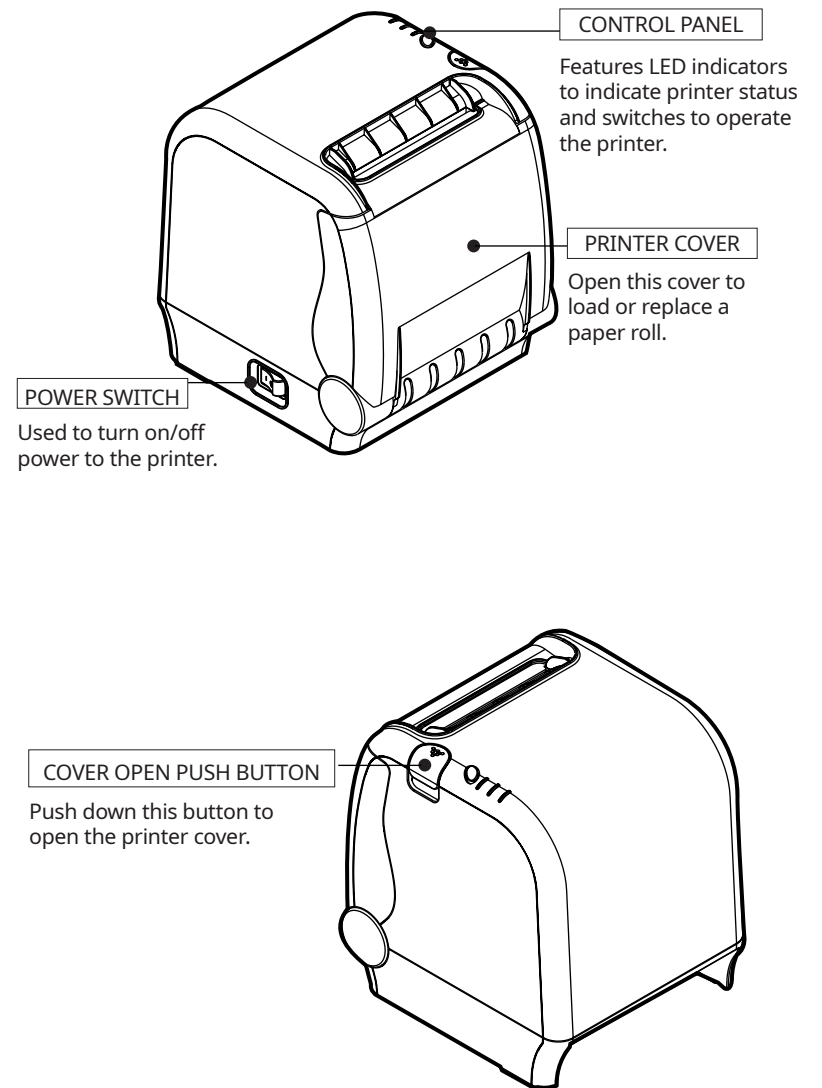

## 2. Setting Up the Printer

### 2-1. Unpacking

Your printer box should include these items. If any items are damaged or missing, please contact your dealer for assistance.

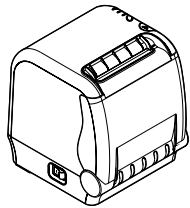

The Printer

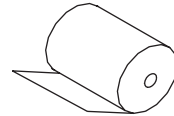

Roll Paper

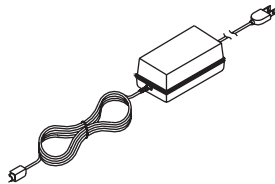

Adaptor(option)

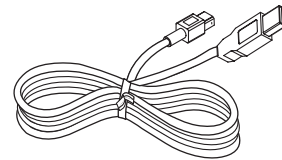

USB Cable(option)

### 2-2. Connecting the Cables

All cables connect to the connector panel on the back of the printer which is shown below:

#### SLK-TS400, SLK-TS400B, SLK-TS400W

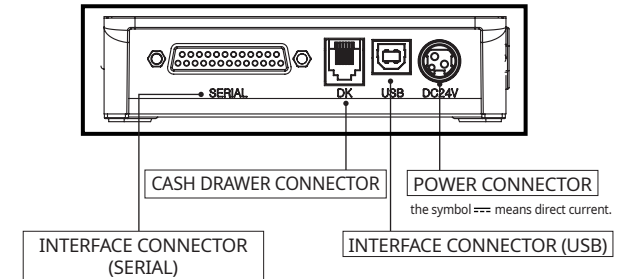

#### SLK-TS400EB, SLK-TS400EBB, SLK-TS400EBW

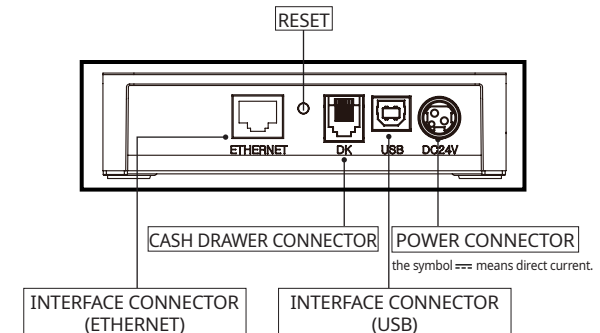

Before connecting any of the cables, make sure that both the printer and the computer are turned off.

## 2-2-1. Interface Connector

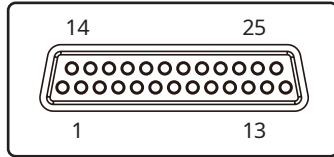

D-SUB 25 Female Serial

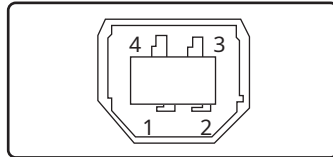

USB "B" Type

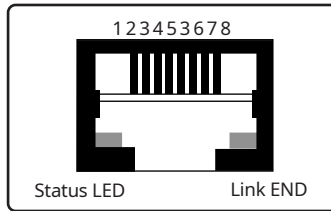

Ethernet

### Ethernet Interface

PIN	SIGNAL	I/O
1	Data Out +	Output Data +
2	Data Out -	Output Data -
3	Data IN +	Input Data +
4	N.C	
5	N.C	
6	Data IN -	Input Data -
7	N.C	
8	N.C	

### 25Pin Serial Interface

PIN	SIGNAL	I/O	Description
2	TxD	Output	Printer transmit data line
3	RxD	Input	Printer receive data line
4, 20	DTR	Output	Data Terminal Ready
6	DSR	Input	Data Set Ready
1, 7	GND	-	System Ground

### USB Interface

PIN	SIGNAL	I/O	Description
1	+5V	-	+5V
2	DATA-	-	Printer transmit data line
3	DATA+	-	Printer transmit data line
4	GND	-	System Ground

## 2-2-2. Cash Drawer Connector

The printer can operate two cash drawers with a 6 pin RJ-11 modular connector. The driver is capable of supplying a maximum current of 1.0A for 510ms or less when not printing.

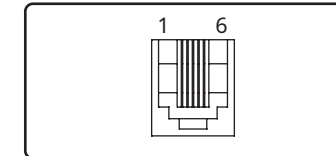

PIN	SIGNAL	Description
1	Signal GND	-
2	Drawer kick-out drive signal 1	Output
3	Drawer open/close signal	Input
4	+24V	-
5	Drawer kick-out drive signal 2	Output
6	Signal GND	-

#### NOTE

Cash drawer 1 and 2 are connected each other inside the printer.

As it is not able to distinguish between Cash drawer 1 and 2, we recommend you to use only one cash drawer.

## 2-3. Loading the Roll Paper

### NOTE

Be sure to use paper rolls that meet the specifications. Do not use paper rolls that have the paper glued to the core because the printer cannot detect the paper end correctly.

### Turn off power switch.

- 1 Make sure that the printer is not receiving data; Otherwise, data may be lost.
- 2 Open the printer cover by pushing down the cover open push button.

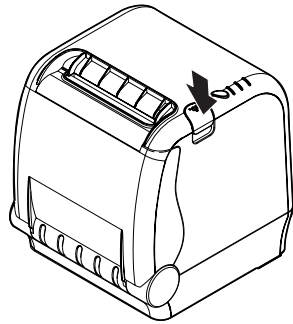

- 3 Remove the used paper roll core if there is one inside.
- 4 Insert new paper roll as shown.

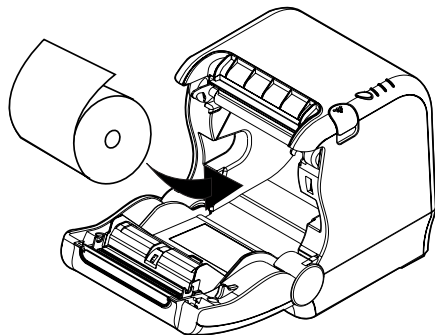

- 5 Note the correct direction that the paper comes off the roll:

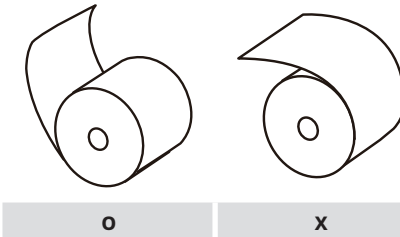

- 6 Pull out a small amount of paper roll as shown. Then, close the cover.

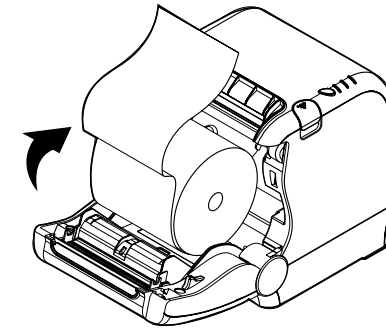

- 7 Tear off the paper as shown.

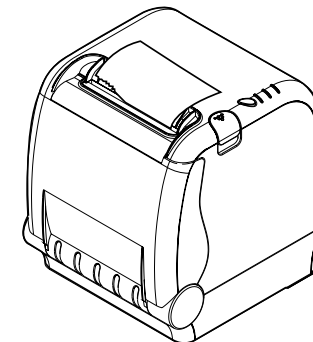

**CAUTION:**

When the cutter is jammed, please follow the steps below.

- 1 Turn off the power.
- 2 Press the cover open button and open the cover.  
: Be carefull of cutter blade because the cutter blade might be come out.

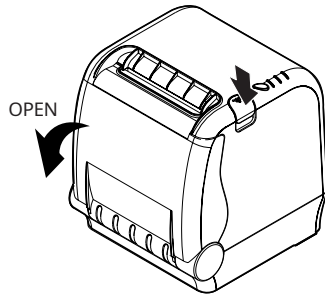

- 3 Turn on the power, the cutter will automatically reset.
- 4 Close the cover.

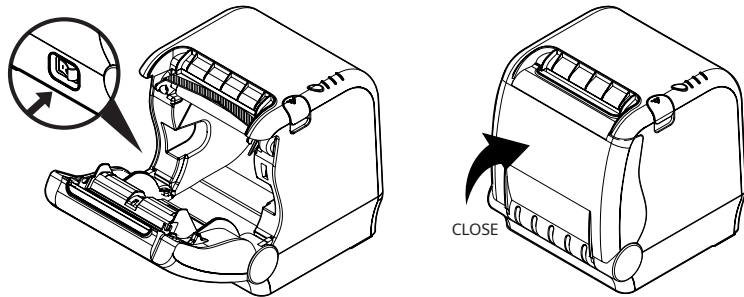

## 3. Control panel and other functions

### 3-1. Control panel

You can control the basic paper feeding operations of the printer with the button on the control panel. The indicator lights let you to monitor the printer's status.

Control Panel

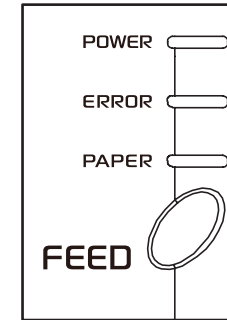

Button

The button can be disabled by the ESC c 5 command.

Press the FEED button once to advance paper one line. You can also hold down the FEED button to feed paper continuously.

### 3-2. Error indicators

STATUS	PAPER	ERROR	POWER	REMARKS
	RED	RED	GREEN	
Power off	OFF	OFF	OFF	Normal power is not supplied to the printer
Power on	OFF	OFF	ON	Normal power is supplied to the printer
On line	OFF	OFF	ON	Normal error-free mode
Cover open	OFF	ON	ON	Close cover
Paper end	ON	ON	ON	Insert new paper roll

## 4. Self Test

The self-test result indicated whether the printer is operating properly. Also with this, user can check following options or status of the printer.

Control circuit
Printer mechanism
Printing quality
ROM version
Interface setting

This test is independent of any other equipment or software.

### Running the self test

- 1 Make sure the printer is turned off and the printer cover is closed properly before performing the self test.
- 2 Turn the printer on holding the FEED button, then the self-test will start. The self-test prints the printer setting value and then prints the following, and pauses. (Error LED On)

SELECT MODE BY BUTTON
1. ASCII PRINT
2. ECO MODE
3. PRINTER SETTING
4. HEXADUMP MODE

- 3 Press the FEED button consecutively (1~4)

1. ASCII PRINT (press the FEED button once)	Printing test page constructed with ASCII code.
2. ECO MODE (press the FEED button twice)	Set the ECO mode for saving paper and power. (Default font type, Reduce paper margin, Density)
3. PRINTER SETTING (press the FEED button triple time)	Set the printer option. (Serial baudrate, Cutting mode, Error beep, Melody)
4. HEXADUMP MODE (press the FEED button quad time)	Printing the HEX value received from the interface

※ Wait for 5~6 seconds if you want to exit. Printer performs a cutting when exiting this mode

- 4 The printer is ready to receive data after finishing setting.

## 5. ASCII Print

ASCII PRINT is printing a test page constructed ASCII code. You can able to check the printer works properly with this

The ASCII PRINT test automatically ends and cuts the paper after printing the following:

**\*\*\* Completed \*\*\***

The printer is ready to receive data as soon as it completes the ASCII PRINT.

## 6. ECO Mode

After entering the ECO MODE, the list which can select the ECO option will be printed. Similar like Self Test, you can press the FEED button to select a ECO option.

Once the input performs properly, the printer shows a result and store.

ECO MODE
1. FONT SETTING
2. LINE SPACE SETTING
3. LINE FEED SETTING
4. BARCODE[1D] HEIGHT
5. DENSITY SETTING

### 6-1. Font

FONT SETTING menu can be change the Font mapping(FONT A / FONT B).

If you did not want other side font, you can disable that.

- FONT A : 12x24
- FONT B : 9x17

FONT SETTING
1. FONT A -> A / FONT B -> B
2. FONT A -> B / FONT B -> B
3. FONT A -> A / FONT B -> A
4. FONT A -> B / FONT B -> A

## 6-2. Paper Reduce

---

Reduce menu (Line space, Line feed, barcode[1D] height) was developed for paper saving.

- Line space  
"Line space" means the amount of feed when you intentionally generate newlines.
- Line feed  
"Line feed" means the amount of feed when there is an automatic line break.
- Barcode Height  
"Barcode Height" means the height of the barcode when creating a one-dimensional barcode.

### LINE SPACE SETTING

- 01 NORMAL
- 02 REDUCE 50%
- 03 REDUCE 75%
- 04 REDUCE 90%

### LINE FEED SETTING

- 01 NORMAL
- 02 REDUCE 50%
- 03 REDUCE 75%
- 04 REDUCE 90%

### 1D BARCODE HEIGHT SETTING

- 01 NORMAL
- 02 REDUCE 50%
- 03 REDUCE 75%
- 04 REDUCE 90%

## 6-3. Density

---

Adjust the print density to save the power consumed by the printer.

### SELECT DENSITY

- 01 NORMAL
- 02 LOW
- 03 DARK

# 7. Printer Setting

Change the printer settings. The options below can also be changed via the Memory Saver.

### PRINTER SETTING

- 01 SELECT BAUDRATE
- 02 SELECT CUTTING MODE
- 03 SELECT ERROR BEEP OPTION
- 04 SELECT MELODY OPTION

## 7-1. Baudrate

---

After entering the BAUDRATE MODE, the list which can select the BPS will be printed. Similar like Self Test, you can press the FEED button to select a BAUDRATE. Once the input performs properly, the printer shows a result and store. The printer is ready to receive data as soon as it completes the SELECT BAUDRATEMODE.

### SELECT BAUDRATE

- 01 4800bps
- 02 9600bps
- 03 19200bps
- 04 38400bps
- 05 57600bps
- 06 115200bps

## 7-2. Cutter

---

Set cutter mode.

### SELECT CUTTING MODE

- 01 PARTIAL CUT
- 02 FULL CUT

## 7-3. Error Beep

---

If the cover is open or there is no paper, the error beep function is activated. This option allows you to enable / disable the error beep.

### SELECT ERROR BEEP OPTION

- 01 BEEP ON
- 02 BEEP OFF

## 7-4. Melody

To DK Port (Cash), Melody box or external buzzer can be connected.

You can activate it from the Melody Setting menu, and the melody will operate after the cutting operation.

- Melody Box : Melody is fixed and volume can be adjusted.
- External Buzzer : 3 types of melody are output according to the Melody Type setting and volume control is not included

### SELECT MELODY OPTION

- 01 MELODY SETTING
- 02 SELECT MELODY TYPE

### MELODY SETTING

- 01 MELODY ON AFTER CUTTING
- 02 MELODY OFF

### SELECT MELODY TYPE

- 01 MELODY- I
- 02 MELODY- II
- 03 MELODY-III

## 8. Hexadecimal Dump

This feature allows experienced users to see exactly what data is coming to the printer. This can be useful in finding software problems.

When you go into the hex dump function, the printer prints all commands and other data in hexadecimal format along with a guide section to help you find specific commands.

### To use the hex dump feature, follow these steps

- 1 Please turn printer off.
- 2 Please turn printer on while press down "Feed" button.
- 3 Press the FEED button three times when the Self Test printed.
- 4 Now printer had entered into Hexa dump mode.
- 5 Run any software program that sends data to the printer. The printer prints "Hexadecimal printing mode..." and then all the codes it receives in a two-column format. The first column contains the hexadecimal codes and the second column gives the ASCII characters that correspond to the codes.

### Hexadecimal Dump

```
1B 21 00 1B 26 02 40 40 !.& . @ @
```

```
1B 25 01 1B 63 34 00 1B .%..c4 ..
```

```
41 42 43 44 45 46 47 48 ABCDEFGH
```

A period (.) is printed for each code that has no ASCII equivalent.

- 6 Turn off the printer.
- 7 Turn on the printer.

This product can communicate with other devices via Bluetooth or Wi-Fi communication and cable.

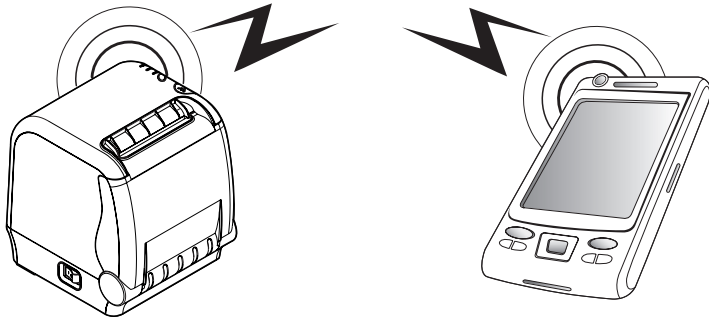

### 9-1. Bluetooth Connection *Optional*

- 1 The Printer can be connected to devices equipped with Bluetooth communication capacity(PDAs, PCs, etc.)
- 2 Use the Bluetooth connection function supported by the device to connect to the printer.

### 9-2. Wi-Fi Connection *Optional*

- 1 The Printer can be connected to devices equipped with Wi-Fi communication capacity(PDAs, PCs, etc.)
- 2 Use the Wi-Fi connection function supported by the device to connect to the printer.

#### NOTE

Please refer to the configuration manual for details.

## 10. Printer Cleaning

If the interior of the printer is dusty, printing quality can be lowered. In this case, follow the instructions below to clean the printer.

#### NOTE

- 1 Make sure to turn the printer power off prior to cleaning
- 2 Regarding print head cleaning, as the print head is very hot during printing, turn off the printer power and wait approximately 10 minute before start.
- 3 When cleaning the print head, take care not to touch the heated part of the print head. The print head subject to be damaged by static electricity.
- 4 Take care not to allow the print head to become scratched and /or damaged in any way.

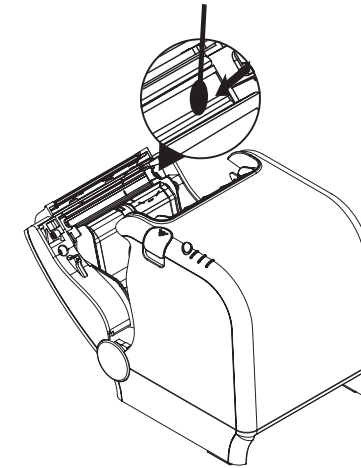

- 1 Use an applicator swab moistened with an alcohol solution to clean the print head and remove any dusts.
- 2 Once the cleaning is completed, insert paper roll into the printer few minutes later and close the printer cover.

#### Preventing Overheating

To prevent the motor from overheating, continuous operation of the printer should be 1.5 m or less in print length. Set the pause time for 30 seconds or more than it.

# 11. Specifications

Printing Method		Direct Thermal
Printing Speed		Max. 220 mm/sec
Resolution		180 DPI
Dot Pitch		0.141mm x 0.141mm
Printing Width		Max. 72mm
Number of print columns		Font A - 42 columns / Font B - 56 columns
Barcode	1D	EAN-8, EAN-13, Code 39, Code 93, Code 128,ITF, UPC-A, UPC-E, Codabar
	2D	PDF 417, QR code, DATA MATRIX
Emulation		ESC/POS Command compatible
Driver		Windows Driver(XP ~, Server2003 ~), Windows CE & Mobile Driver(CE 4.2 ~, Mobile 5.0 ~), Linux Driver, Mac Driver, OPOS Driver, JavaPOS Driver, iOS SDK, Android(6.0 ~) SDK, Windows SDK, Windows CE SDK, Linux SDK
Sensor		Paper end, Cover open
Paper	Paper type	Thermal receipt paper
	Width	Max. 83mm
	Thickness	0.06 ~ 0.09mm
	Roll Max Diameter	Max. 83mm
	Roll Core	12.5mm ± 0.5mm
Interface	Standard	TS400 : USB(B type)+Serial(RS-232C_25pin) Built-in TS400EB : USB(B type)+Ethernet Built-in
	Option	TS400 :Wi-Fi(802.11a/b/g/n), Bluetooth Ver 4.2(Movon,iOS) TS400EB : Wi-Fi(802.11a/b/g/n), Bluetooth Ver4.2(Movon,iOS)

Cash drawer		1 circuits(24V, 1A Max.)
Reliability	MCBF	60 million lines
	TPH Life	160Km
Cutter	Type	Guillotine
	Life	1,500,000 cuts
	Paper Thickness	0.06 ~ 0.09mm
Power	AC	100 ~ 240Vac 50/60 Hz
	DC	24Vdc / 1.75A
Size		130 x 140 x 154 [W x D x H (mm)]
Weight		1.25kg
Temperature	Operation	0 ~ 45°C
	Storage	-20 ~ 60°C
Humidity	Operation	35 ~ 80%
	Storage	10 ~ 90%





## 13. Utilities

The following utilities and concerned manual can be found on the QR or homepage.

No.	Name	Description
1	Memory Saver	This is a utility that allows you to set printers by interface. Detailed settings such as Wi-Fi, Ethernet, and COM ports can be configured.
2	NV Logo Upload	With NV Logo Upload running on Windows OS, you can upload and remove the bmp file as Logo in the printer's flash memory, and print test is possible.
3	Download Tool (F/W)	Printer F/W and Font Download are available, and BT, Wi-Fi module F/W Download is supported as an option.
4	Android Utility (Sewoo M_Utility)	It is a utility app that prints text, barcodes, images, etc. through Bluetooth and Wi-Fi communication, and able to printer settings.

## 14. S/W

We provides SDK, Driver, etc. as follows to respond to various S/W usage environments.

You can download this S/W from the homepage.

No.	Name	Description
1	Windows Driver	This is an install program used to print a POS printer in Windows OS.
2	Linux Driver	This is the Cups Driver used to print a Thermal printer in the Linux environment.
3	OPOS Driver	This is a driver that controls POS printers using the OPOS standard. It can be used after initial setting(POS Printer&Cash Drawer) using the setting tool.
4	JavaPOS Driver	The JavaPOS driver is an interface standard for POS software written in Java.
5	Mac Driver	This is the Cups Driver used to print a Thermal printer in the Mac OS environment.
6	Android Plugin (Sewoo Print Service Plugin)	This is a print service plug-in that allows you to print documents, images, and web pages without installing additional apps.
7	Windows SDK	This is library for communication and data output with Thermal printer in Windows OS. Can be used through direct communication and driver.
8	Android SDK	This is library for communication and data output with Thermal printers in Android OS.
9	iOS SDK	This is library for communication and data output with Thermal printers in iOS.
10	Linux SDK	This is library for communication and data output with Thermal printers in Linux.