

sewoo

sewoo

Aroot Co., Ltd.

28-6, Gajangsaneopdong-ro, Osan-si, Gyeonggi-do ,18103, Republic of Korea
TEL +82-31-8077-5000 / FAX +82-31-624-5310 / <http://www.miniprinter.com>

B30IIE ENG Rev.A 10/2023



LABEL PRINTER
MODEL : LK-B30IIE

4" Direct Thermal Label Printer

All specifications are subject to change without notice

**This device complies with part 15 of the FCC Rules.
Operation is subject to the following two conditions.**

- 1) This device may not cause harmful interference, and
- 2) This device must accept any interference received, including interference that may cause undesired operation.

Tim Kloeker

20280 S. Vermont Ave. STE 200, Torrance, CA 90502 | USA
NA_Sales@miniprinter.com

Victor Almazan

Paseo de la Reforma No. 265 Piso 2.Oficina SBC. Col.
Cuauhtémoc, C.P. 06500 Ciudad de Mexico | Mexico
LA_Sales@miniprinter.com



Disposal of Old Electrical&Electronic Equipment(Applicable in the European Union and other European countries with separate collection systems)

This symbol on the product or on its packaging indicates that this product shall not be treated as household waste. Instead it shall be handed over to the applicable collection point for the recycling of electrical and electronics equipment. For more detailed information about recycling of this product, please contact your local city office, your household waste disposal service or the shop where you purchased the product.

For USA

Information to user;

Caution: The user that changes or modifications not expressly approved by the Aroot Co., Ltd., responsible for compliance could void the user's authority to operate the equipment.

NOTE: This equipment has been tested and found to comply with the limits for a Class A digital device, pursuant to part 15 of the FCC Rules. These limits are designed to provide reasonable protection against harmful interference when the equipment is operated in a commercial environment. This equipment generates, uses, and can radiate radio frequency energy and, if not installed and used in accordance with the instruction manual, may cause harmful interference to radio communications. Operation of this equipment in a residential area is likely to cause harmful interference in which case the user will be required to correct the interference at his own expense.

CAUTION: Radio Frequency Radiation Exposure

This equipment complies with FCC radiation exposure limits set forth for an uncontrolled environment and meets the FCC radio frequency RF Exposure Guidelines. This equipment should be installed and operated keeping the radiator at least 20cm or more away from person's body.

Responsible Party;

Company name : Aroot USA

Address : 19700 S. VERMONT AVE. STE 200 TORRANCE, CA 90502

Tel/FAX No : +1-310-617-7401

Homepage : miniprinter.com

For Canada

This class A digital apparatus complies with Canadian ICES-003 (A)
Cet appareil numérique de la classe A est conforme la norme NMB-003 (A) du Canada
The antenna cannot be removed (and changed) by user.

NOTE

This device contains licence-exempt transmitter(s)/receiver(s) that comply with Innovation, Science and Economic Development Canada's licence-exempt RSS(s). Operation is subject to the following two conditions: (1) This device may not cause interference. (2) This device must accept any interference, including interference that may cause undesired operation of the device.

CAUTION: Radio Frequency Radiation Exposure

This equipment complies with IC radiation exposure limits set forth for an uncontrolled environment and meets RSS-102 of the IC radio frequency (RF) Exposure rules. This equipment should be installed and operated keeping the radiator at least 20cm or more away from person's body.

Table of Contents

Safety Precautions	2
1. Unpacking	4
2. Inspecting The Printer	5
3. Connecting power supply	7
4. Hooking up the printer and computer	8
5. Loading the media	9
5-1. Roll paper Type	9
5-2. Fanfold Type	11
5-3. Load Fanfold Cover	13
5-4. Remove Fanfold cover	14
6. The treatment when you run short of paper and encounter cutter jam problem	15
7. Setting up the sensors	16
8. Self-Test Printing / Configuration Printout	17
8-1. Self-Test printing when printer power is off	17
8-1. Self-Test printing when printer power is on	18
9. Media Calibration	19
9-1. Media Calibration when printer power is off	19
9-2. Media Calibration when printer power is on	20
10. Offline Printer Reset Function	21

Safety Precautions

For better safety and reliability, adhere to the following precautionary measures. Read and follow the instructions carefully before operation of the product.

Indication



Prohibition



Must follow



Do not disassemble



Unplug the power from the outlet



Grounding to prevent electric shock



Do not handle the product with wet hands



WARNING

Failure to follow these instructions could result in fire, electric shock, other injuries, or property damage.



Do not pull or touch the power plug with wet hands.

Potential risk of electric shock or fire



Do not bend the wire and do not allow the wire to be pinched or crushed by heavy objects.

Potential risk of electric shock or fire

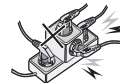

Do not overload an electrical outlet.

Potential risk of electric shock or fire

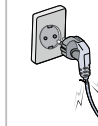

If a power plug is broken or a plug is cut or worn, do not use it.

Potential risk of electric shock or fire



11. Option	22
11-1. Cutter Assembly	22
11-2. Peeler Assembly	25
12. Printer cleaning	28
13. Peripheral Connection (Optional)	29
13-1. Bluetooth Connection	29
13-2. Wi-Fi Connection	29
14. Connector	30
15. Standard roll media specification	32
16. Standard label specification	33
17. Label specification with Through-hole	34
18. Label with Black Mark	35
19. Continuous stock specification	36
20. Specifications	37
21. Command List	39
22. Utilities	42
23. S/W	43



WARNING

Failure to follow these instructions could result in fire, electric shock, other injuries, or property damage.



Do not unplug the power cable to turn off the product.

Turn off the power using the power button



Do not disassemble, repair or modify the product.

Potential risk of malfunction, electric shock, or fire. When the product needs to be repaired, please contact your reseller



CAUTION

Failure to follow these instructions could result in fire, electric shock, other injuries, or property damage.



Do not install the product on an unstable or inclined surface.

May cause damage or injury



If the product needs to be repaired, please contact your reseller.

Potential risk of fire or unit malfunction



Keep product away from the water and other material.

Potential risk of fire or unit malfunction

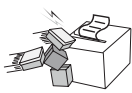

Avoid excessive shock or drops.

Potential risk of fire or property damage



1. Unpacking

Standard

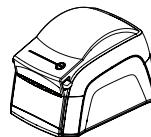

Printer



Fanfold Cover

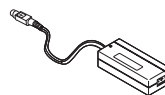

Power Supply

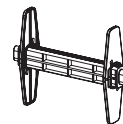

Paper Spindle

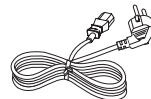

Power Cord



Manual

Optional



Auto Cutter

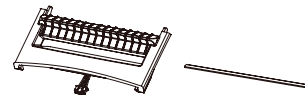

Peeler & Peeler bar

2. Inspecting The Printer

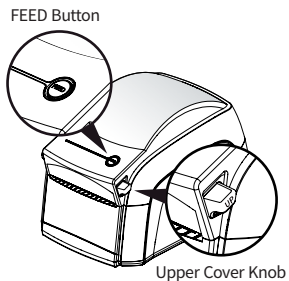
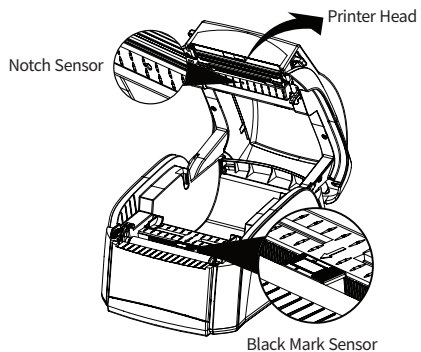
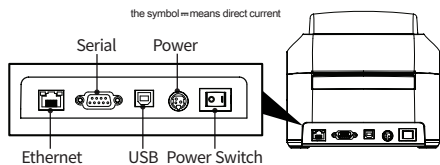

Opening the printer

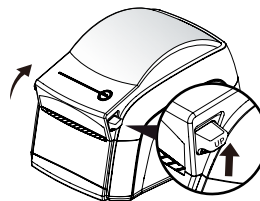

Open the upper cover by pushing the knob in the direction of the arrow.

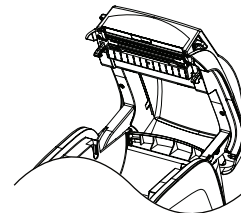

CAUTION
Make sure to be careful of the HOT head after using long time.

1 2
3

"If the cover is not shut down completely, the printer may not work properly"

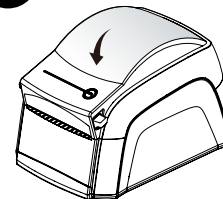

Please make sure you hear the closing sound of the upper cover.

3. Connecting power supply

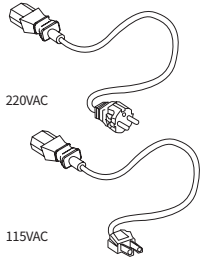

Please check the specification of the AC power cord if it is correct with your power system.

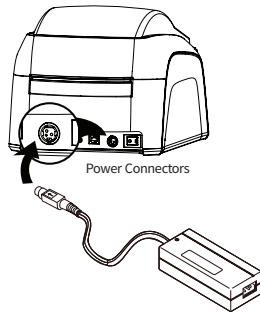

Turn off the power of the printer and connect the power supply to the printer as shown above.

1 2
3 4

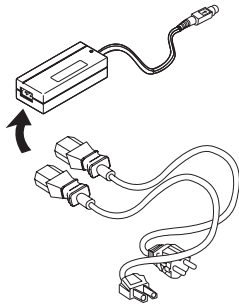

Connect the AC power cord to the power supply.

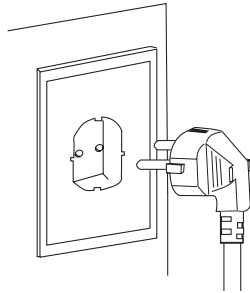

Insert a plug into the electrical outlet.

4. Hooking up the printer and computer

Printer

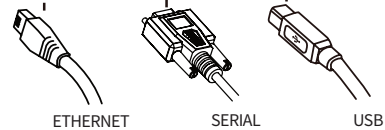
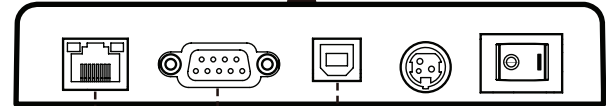
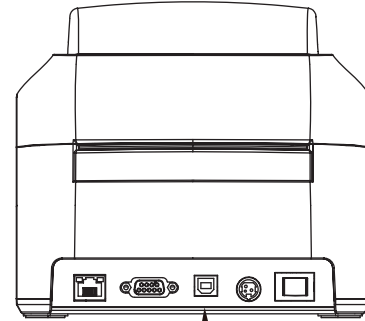

ETHERNET

SERIAL

USB

5. Loading the media

5-1. Roll paper Type

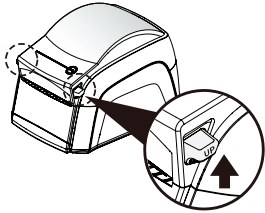

Turn off the printer and open the upper cover by pushing the knob in the direction of the arrow.

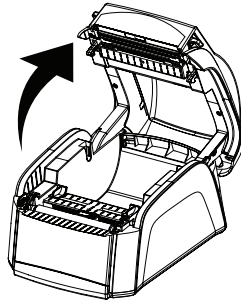

Please open the upper cover as shown above.

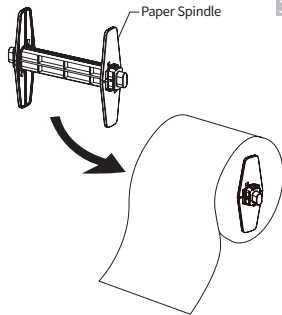

Paper Spindle

1 2
3 4

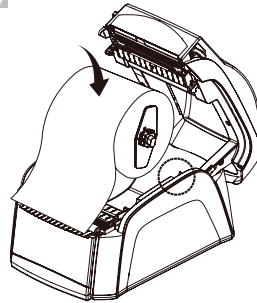

Insert paper roll into the printer.

Pull out one of the adjustable width tabs. Insert a paper roll and adjust the tab so that the paper can be positioned in the center.

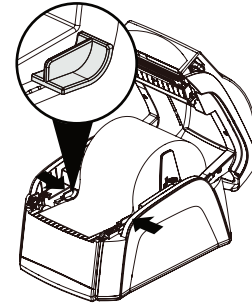

Adjust the paper guide to fit the width of the paper.

5
6

" Please cut the paper in upper direction "

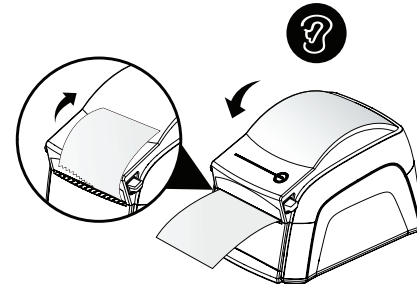

Pull the paper to the print position and Make sure that you hear the closing sound when the top cover is fully closed.

5-2. Fanfold Type

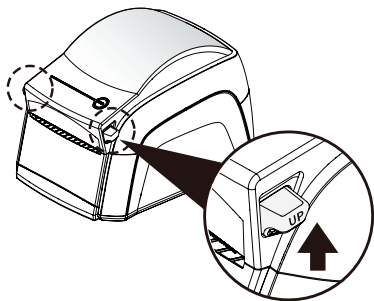

Turn off the printer and open the upper cover by pushing the knob in the direction of the arrow.

1
2

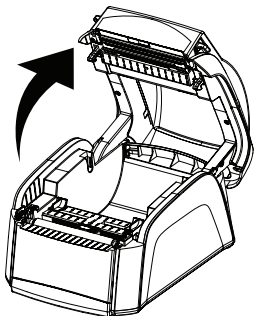

Please open the upper cover as shown above.

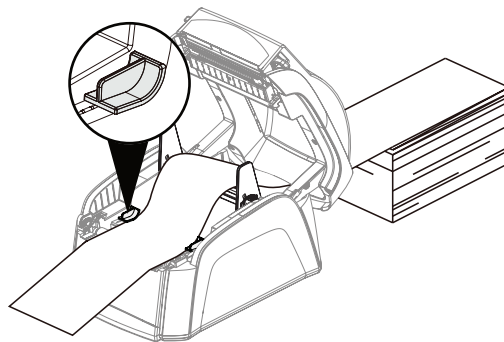

Insert a paper roll into the printer.

3
4

" Please cut the paper
in upper direction "

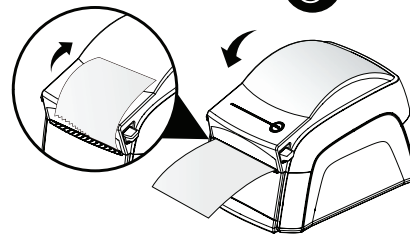

Close the upper cover completely.

– Make sure you hear the closing sound.

5-3. Load Fanfold Cover

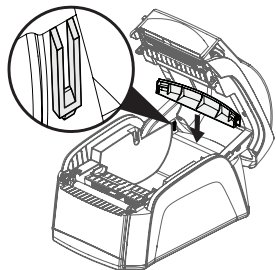

Open the upper cover and put the Fanfold cover into the guide hook as shown above.

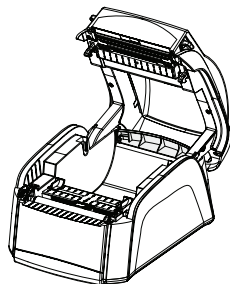

Pushing fanfold cover from up to down and set.

1 2

Back side of printer loaded fanfold cover

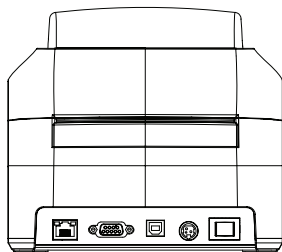

5-4. Remove Fanfold cover

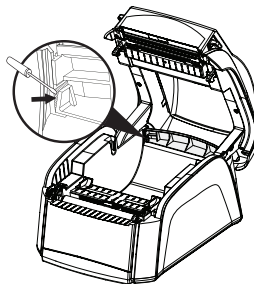

Pull out the left edge of the fanfold cover using an angled tool.

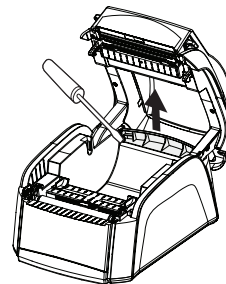

When the edge widens, pull the fanfold cover upwards to remove it.

1 2

Back side of printer removed fanfold cover

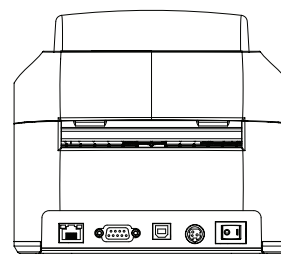

NOTE

- Please remove fanfold cover when using fanfold type paper.

6. The treatment when you run short of paper and encounter cutter jam problem

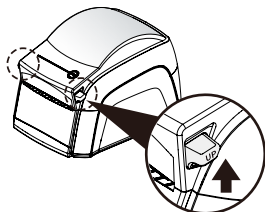

While you are printing with continuous media, please press PULL lever to the direction of the arrow.

" Installation of the new paper when the printer is short of it "

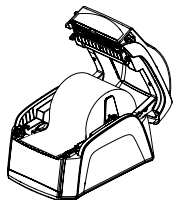

" Remove of the paper seized by paper jam "

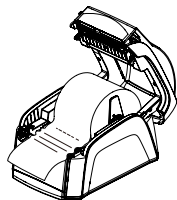

" Remove the paper seized by paper jam "

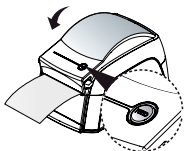

After the treatment has been done as picture above, the printer function normally once you press FEED button.



Caution

When the power is on, the ordered data will be printed without any data lost after installation of the new paper roll or treatment for paper Jam.

However, if these action has been done in the case the power is off, there can be some data lost since the printer buffer will not save them while the printer power is off.

7. Setting up the sensors

Black Mark Sensor

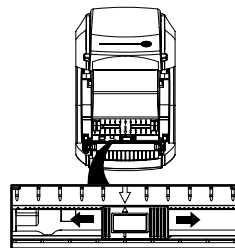

Set Black Mark Sensor right to the size of roll paper.

Notch Sensor

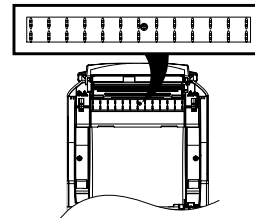

The sensor is fixed, so no further adjustment is required.

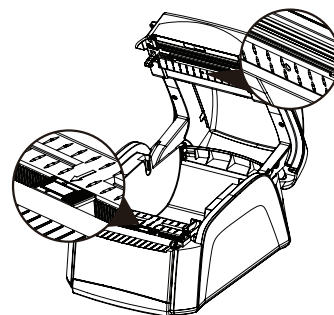

Adjust the arrows to face each other in the same position.

8. Self-Test Printing / Configuration Printout

8-1. Self-Test printing when printer power is off

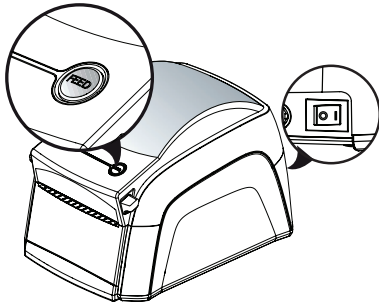

- 1 While pressing the “FEED” button, power on the printer and then release the “FEED” button at the start of printing.
- 2 After the printout is completed, printer returns to the READY mode.

☑ NOTE

– Power Switch meaning — ON ○ OFF

8-2. Self-Test printing when printer power is on

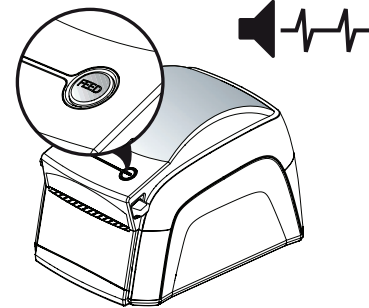

- 1 Press the “FEED” button until after the sound of two beeps. Then release the “FEED” button.
- 2 After the printout is completed, printer returns to READY mode.

☑ NOTE

– If the “FEED” button is released after only one beep, the printer goes into the Media Calibration function. (see section 9)

9. Media Calibration

9-1. Media Calibration when printer power is off

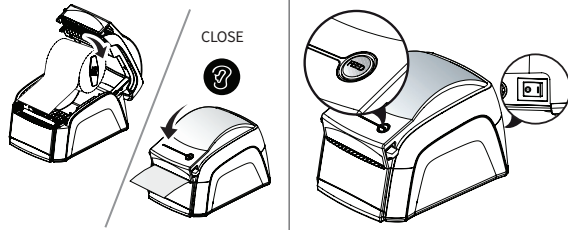

With the printer turned off, load paper and close the printer cover.

While pressing the "FEED" button, power on the printer the start of printing.

1 2
3

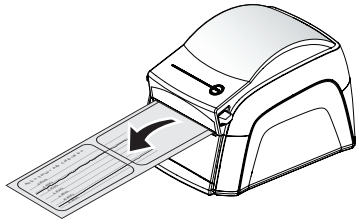

The printer is going to print out the media with the graph indicating how calibration is done for the sensor. This information will be automatically saved to ensure the accuracy on the form alignment. Once the graph is printed, cycle the power to get back into to READY mode.

✓ NOTE

- If the printing result is abnormal after the media calibration, please use the "SEWOOD Label Printer Configuration Tool" to configure correctly. This utility is on the CD or can be downloaded from the printer's web page, at the bottom under "Utility".

9-2. Media Calibration when printer power is on

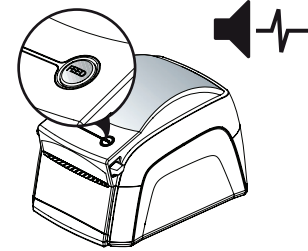

Press the "FEED" button and release immediately after the first beep.

✓ NOTE

- At the sound of the second beep, the printer goes into the Self Test function and prints out the printer's configuration.

1
2

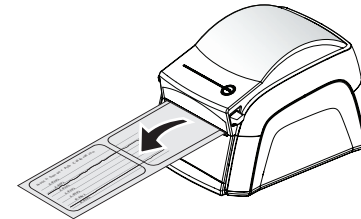

The printer is going to print out the media with the graph indicating how calibration is done for the sensor. This information will be automatically saved to ensure the accuracy on the form alignment. Once the graph is printed, cycle the power to get back into to READY mode.

10. Offline Printer Reset Function

- The LK-B30IIE can be reset without being connected to the computer.

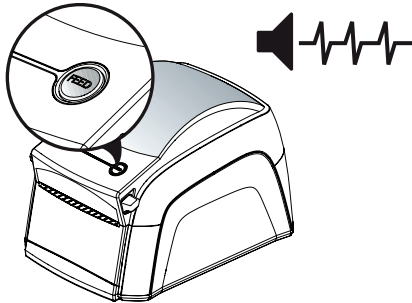

- 1 With the printer powered on, pressing the “FEED” button will produce a beep sound every 1 second. Hold the “FEED” button and release at the third beep to enter the printer reset function. The printer will then print a menu and will then enter into the offline reset mode.
- 2 Review the menu (as shown below) and press down the “FEED” button the number of beeps corresponds to the item to be executed in the menu, and then release the “FEED” button.

Setting Menu

- 01 Ethernet setting initialization
- 02 Printer Factory Reset
- 03 Enter printer offline reset mode

NOTE

- Printing or feeding while in the offline setting menu will cause the printer to exit this menu option.
- This function is supported from firmware version V3.00 and higher.

11. Option

11-1 Cutter Assembly



This equipment is not suitable for use in locations where children are likely to be present.



Moving parts

- ※ Keep body parts away from cutter blades.

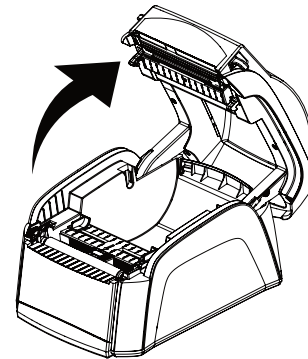

- 1 Open the paper cover.

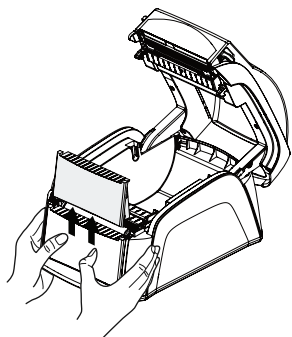

Lift the front cover to disassemble.

2
3 4

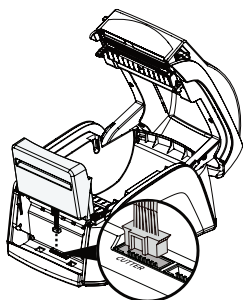

Connect the cutter connector to cutter position.

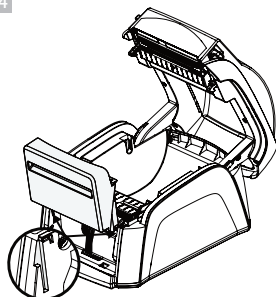

Assemble the cutter to the left and right connections and install it down.

✓ NOTE

– left and right positions are correctly Assembled.

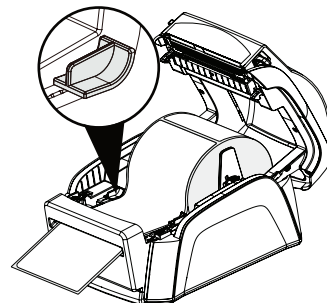

After passing the paper through the cutter mechanism, adjust the guide to fit the width.

5
6

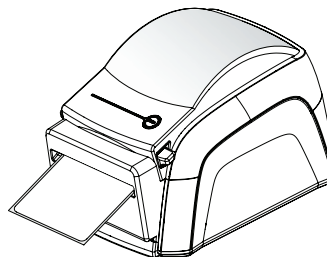

Close the paper cover.

11-2 Peeler Assembly

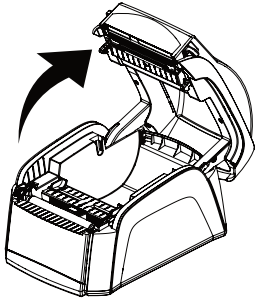

Open the paper cover.

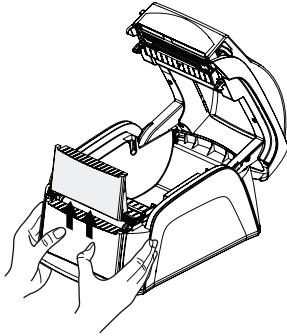

Lift the front cover to disassemble.

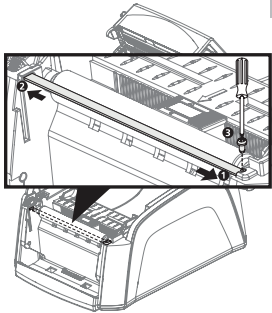

Fix the peeler bar according to the order as shown in the picture.

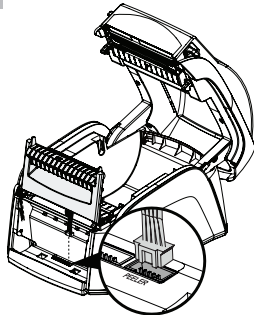

Connect the peeler connector to peeler position.

1 2
3 4

NOTE

– left and right positions are correctly Assembled.

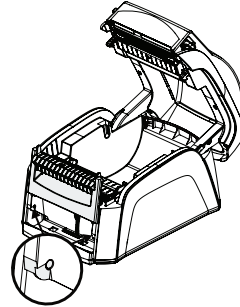

Assemble the filler to the left and right connections and install it down.

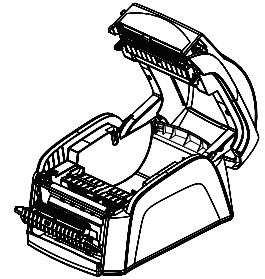

Open the peeler to the front as shown.

5 6
7 8

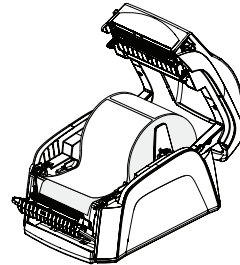

Please put the paper in and remove the label.

Move the peeled backing paper to the outlet under the peeler roller.

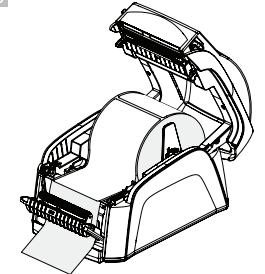

Move the backing paper that has passed through the rollers forward.

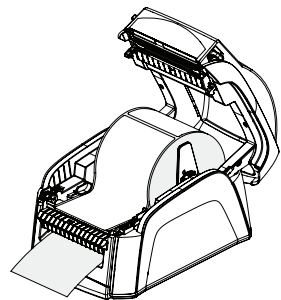

Return the peeler mechanism to normal position.

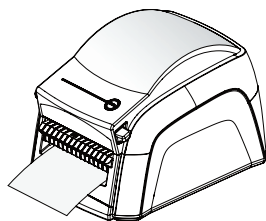

Close the paper cover.

9 10
11

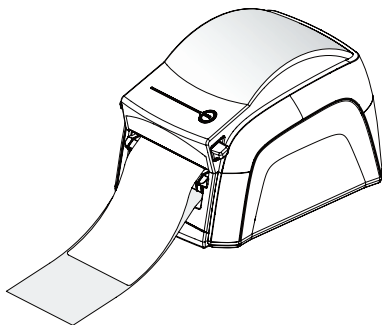

It is recommended that you use it after checking if the label paper and the back paper are separated when the printout is printed.

12. Printer cleaning

If the interior of the printer is dusty, printing quality can be lowered.

In such a case, follow the instructions below to clean up the printer.

NOTE

- 01 Make sure to turn the printer power off prior to cleaning.
- 02 Regarding printhead cleaning, as the printhead gets very hot during printing, turn off the printer power and wait approximately 10 minutes before cleaning.
- 03 When cleaning the printhead, take care not to touch the heated portion of the printhead. The printhead can be damaged by static electricity.
- 04 Take care not to allow the printhead to become scratched and / or damaged in any way.

Print-Head Cleaning

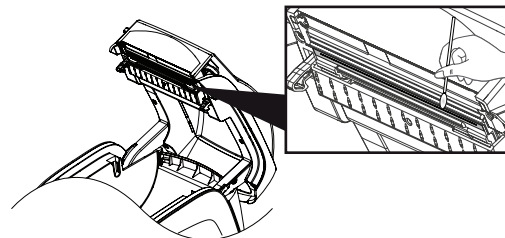

- 1 Use an applicator swab moistened with an alcohol solution to clean the print head and remove any dusts.
- 2 Once the cleaning is completed, insert paper roll into the printer few minutes later and close the printer cover.

13. Peripheral Connection (Optional)

This product can communicate with other devices via Bluetooth & Wi-Fi communication and cable.

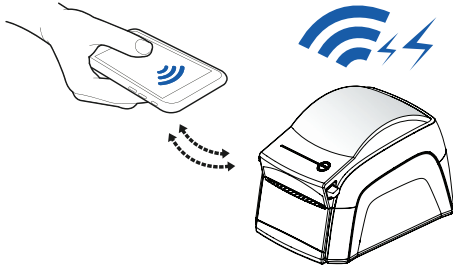

13-1. Bluetooth Connection

- 1 The Printer can be connected to devices equipped with Bluetooth communication capabilities (PDAs, PCs, etc.).
- 2 Use the Bluetooth connection function supported by your device to connect to the printer.

13-2. Wi-Fi Connection

- 1 The Printer can be connected to devices equipped with Wi-Fi communication capabilities (PDAs, PCs, etc.).
- 2 Use the Wi-Fi connection function supported by the device to connect to the printer.

NOTE

- Please refer to the configuration manual for details.
- Website(www.miniprinter.com) > C/S Center > Download > Select Model

14. Connector

Interface Connectors

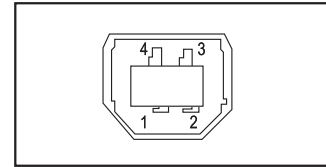

USB "B" TYPE

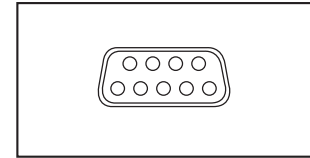

9 Pin Serial

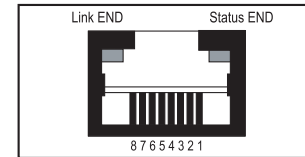

Ethernet

15. Standard roll media specification

Ethernet Interface

Pin	Signal	I/O
1	Data Out +	Output Data +
2	Data Out -	Output Data -
3	GND	Ground
4	Data IN +	Input Data +
5	Data IN -	Input Data -
6	N.C	-
7	N.C	-
8	N.C	-

USB Interface

Pin	Signal	I/O	Description
1	+5V	-	+5V
2	DATA-	-	Printer transmit data line
3	DATA+	-	Printer transmit data line
4	GND	-	System Ground

9Pin Serial Interface

Pin	Signal	I/O	Description
3	RXD	Input	Printer receive data line RS-232C level
2	TXD	Output	Printer transmit data line RS-232C level
6,8	DTR	Output	Printer handshake to host line RS-232C level
5	GND	-	System Ground
4	DSR	Input	Data Send Ready
1,7,9	NC	-	-

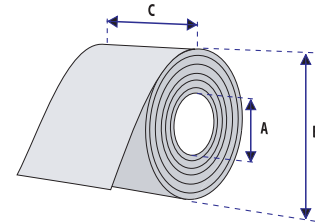

Core	
Diameter(A)	25.4 mm
Max. width	116 mm
Roll	
Max.diameter(B)	127 mm
Max.media width(C)	116 mm
Min.media width(C)	25.4 mm
Max.media thickness	0.20 mm
Min.mdeia thickness	0.06 mm

NOTE

- 01 When the paper width is less than 25.4 (1inch), please print 101.6 mm/s.
- 02 When the paper width is between 25.4 (1inch) to 76.2 (3inch), please print 127mm/s.

※ Motor protection from being overheated

To prevent the motor from overheating, stop the printer for at least 30 seconds after continuously printing 2 meters.



Protect the media against sand, grit, and other hard particles during printing and storage. Keep the cover closed. Even very small foreign particles may cause severe harm to the delicate printhead.

16. Standard label specification

<- a -> Media width (inch, liner)	
Maximum	116 mm
Minimum	25.4 mm
<- b -> Label gap height	
Maximum	10 mm
Minimum	2 mm

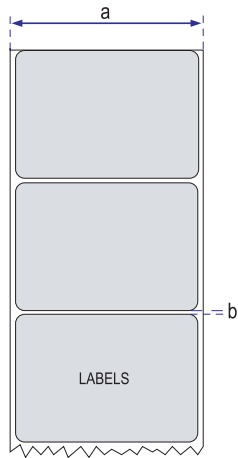

17. Label specification with Through-hole

<- a -> Tag or strip width	
Maximum	116 mm
Minimum	25.4 mm
<- b -> Detection slot width	
Minimum	14 mm
<- c -> Detection slot height	
Maximum	10 mm
Minimum	2 mm

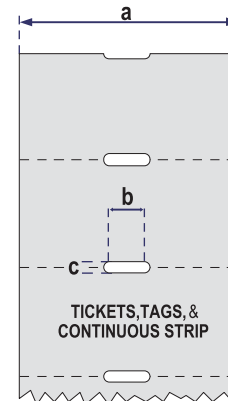

18. Label with Black Mark

<- a -> Tag or strip width	
Maximum	116 mm
Minimum	25.4 mm
<- b -> Black mark width	
Minimum	14 mm
<- c -> Black mark height	
Maximum	10 mm
Minimum	3 mm

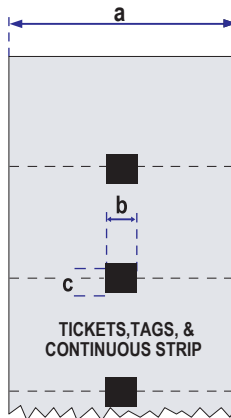

19. Continuous stock specification

The printer can use continuous paper without any detection gap or black marks.

The printer must be set for continuous paper by the Q command.

The length of each copy is decided by the size of the print image and any additional media feed is decided by the Q command.

Continuous paper cannot be used in the Test (Dump) Mode.

<- a -> width	
Maximum	116 mm
Minimum	25.4 mm



20. Specifications

Print method		Direct Thermal
Print speed (Max.)		152mm/sec
Print width (Max.)		108mm (4.25 inch)
Print length (Max.)		1000mm (39.3")
Resolution		203dpi (8 dots/mm)
Paper width (Min.~Max.)		25.4 ~ 115mm (1" ~ 4.52")
Paper roll size		25.4mm (1")
Paper thickness		0.06 ~ 0.20 mm
Paper type		Roll, Fanfold, Blackmark, Continuous, Gap, punched hole, Notch Sensor
Paper sensor		Label gap, Black mark, Notch
Interface	Standard	USB, Serial(RS-232C), Etherent
	Option	Wi-Fi(802.11a/b/g/n), Bluetooth Smart Ready (Bluetooth4.2+BLE)
Memory		Main Flash 1MB, SDRAM 16MB, FONT Flash 8MB
Serial baud rate(Max.)		115,200 bps (max)
Emulation		EPLII, ZPLII Command compatible
Font specification	EPLII	6 bitmapped - 8x12, 10x16, 12x20, 14x24, 32x48, 24x24(KSC5601)
	ZPLII	9 bitmapped - 5x9, 7x11, 10x18, 10x18, 15x28, 13x26, 40x60, 13x21, 24x24 2 smooth scalable(English, Korean)
Barcode	1D	Code39, Code128 with subsets A/B/C/Auto, UCC/EAN-128, Code93, Codabar, Interleaved 2 of 5, UPC-A, UPC-E, UPC-A and E with 2 or 5 digit extension, EAN-8, EAN-13, EAN-8 and 13 with 2 or 5 digit extensions, Postnet, Plessey, MSI-3, German Post CodeLogmars, Code11, UPC_Interleaved 2 of 5, Industrial 2 of 5, Standard 2 of 5, Planet, ANSI, Logmars
	2D	MaxiCode, PDF 417, Data Matrix, QR Code, MicroPDF417, AZTEC, Code 49, CODABLOCK, RSS

Power	Type	External SMPS
	AC	100 ~240Vac, 1.5A, 50~60Hz
	DC	24 Vdc 2.5A
Operating Temperature		5°C ~ 40°C
Storage Temperature		-20°C ~ 60°C
Weight		3.3lbs (1.52kg)
Size (W x D x H)		190 x 262 x 168 (mm) / 7.48 x 10.31 x 6.61 (Inch)
Option		Auto Cutter, Peeler

Electrical Characteristics

- 1 Input Voltage DC 24V ± 10%
- 2 Power Supply Current 1.75 A
- 3 Power Connector

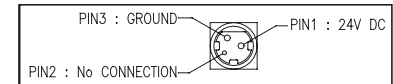

21. Command List

ZPL Command List

No.	Command	Description
1	^A	Scalable/Bitmapped Font
2	^B1	Code 11 BarCode
3	^B2	Interleaved 2 of 5 BarCode
4	^B3	Code 39 BarCode
5	^B4	Code 49 BarCode
6	^B5	Planet Code BarCode
7	^B7	PDF417 BarCode
8	^B8	EAN-8 BarCode
9	^B9	UPC-E BarCode
10	^BA	Code 93 BarCode
11	^BC	Code 128 BarCode(Subsets A, B, and C)
12	^BD	UPS MaxiCode BarCode
13	^BE	EAN-13 BarCode
14	^BF	Micro-PDF417 BarCode
15	^BI	Industrial 2 of 5 BarCode
16	^BJ	Standard 2 of 5 BarCode
17	^BK	ANSI Codabar BarCode
18	^BL	LOGMARS BarCode
19	^BM	MSI BarCode
20	^BP	Plessey BarCode
21	^BQ	QR Code BarCode
22	^BS	UPC/EAN Extensions
23	^BU	UPC-A BarCode
24	^BX	Data Matrix BarCode
25	^BY	BarCode Field Default
26	^BZ	POSTNET BarCode
27	^CC	~CC Change Carets
28	^CD	~CD Change Delimiter
29	^CF	Change Alphanumeric Default Font
30	^CI	Change International Font/Encoding
31	^CT	~CT Change Tilde
32	^DF	Download Format

33	~DG	Download Graphics
34	^FB	Field Block
35	^FC	Field Clock(for Real-Time Clock)
36	^FD	Field Data
37	^FH	Field Hexadecimal Indicator
38	^FN	Field Number
39	^FO	Field Origin
40	^FP	Field Parameter
41	^FR	Field Reverse Print
42	^FS	Field Separator
43	^FT	Field Typeset
44	^FV	Field Variable
45	^FW	Field Orientation
46	^FX	Comment
47	^GB	Graphic Box
48	^GC	Graphic Circle
49	^GD	Graphic Diagonal Line
50	^GE	Graphic Ellipse
51	^GF	Graphic Field
52	^GS	Graphic Symbol
53	^ID	Object Delete
54	^IL	Image Load
55	^IM	Image Move
56	^IS	Image Save
57	^LH	Label Home
58	^LL	Label Length
59	^LR	Label Reverse Print
60	^LS	Label Shift
61	^LT	Label Top
62	^MC	Map Clear
63	^MD	Media Darkness
64	^MM	Print Mode

22. Utilities

The following utilities and concerned manual can be found on the CD or homepage.

No.	Name	Description
1	SEWOO Label Printer Configuration Tool	SEWOO Label Printer Configuration Tool. This program provides the following functions. <ul style="list-style-type: none"> - Set Ethernet and RS232 - Set beep sound for each error - Set detailed sensor calibration conditions - Set the print density, speed, tear-off amount after printing, and operation at booting & cover close action - Download the printer firmware - Download the resident font
2	SEWOO Label Printer Wi-Fi	This program provides detailed Wi-Fi setting functions.
3	SEWOO Label Printer Bluetooth Configuration Tool	This program provides detailed Bluetooth setting functions.
4	Font Downloader (ZPL supported)	This program provides a function to download the device system font to the printer.
5	LabelCooker	This program is for label form design and designed label printing.
6	ImageConverter (ZPL supported)	This program provides a function to download images or logos.

65	^MN	Media Tracking
66	^MT	Media Type
67	^PM	Printing Mirror Image of Label
68	^PO	Print Orientation
69	^PQ	Print Quantity
70	^PR	Print Rate
71	^PW	Print Width
72	^SC	Set Serial Communications
73	~SD	Set Darkness
74	^SN	Serialization Data
75	^ST	Set Date and Time(for Real-Tiime Clock)
76	^XA	Start Format
77	^XF	Recall Format
78	^XG	Recall Graphic
79	^XZ	End Format

23. S/W

We provides SDK, Driver, etc. as follows to respond to various S/W usage environments.

You can download this S/W from the homepage.

No	Name	Description
1	Windows Driver	This is an install program used to print a label printer in Windows OS. After installing the Windows Driver, you can use a program like Label Cooker.
2	Mac Driver (EPL supported)	This is the Cups Driver used to print a label printer in the Mac OS environment.
3	Windows SDK	This is library for communication and data output with label printer in Windows OS. A method that can be used after installing Windows Driver (Windows GDI & Spool SDK) and a method to use without driver installation (Windows Direct SDK) are provided.
4	Android SDK	This is library for communication and data output with label printers in Android OS.
5	iOS SDK	This is library for communication and data output with label printers in iOS.



QR Page